

Electronic stethoscope TMST 3

Easily pinpoints bearing and machine noise

The SKF TMST 3 is a high quality, sensitive instrument enabling the determination of troublesome machine parts by the detection of machine noises or vibrations. TMST 3 includes a headset, two different length probes (70 and 220 mm) and a pre recorded audio CD demonstrating the most common encountered troublesome machine noise, all supplied complete in a sturdy carrying case.



- Excellent sound quality helps to reliably identify the possible cause of the noise
- User friendly and easy to operate, no special training required
- Lightweight ergonomic design makes it easy to operate with one hand
- Excellent quality headset for optimum sound quality even in very high-noise environments
- Pre-recorded demonstration CD and output for analogue recording help facilitate analysis and comparison
- Supplied with two probes, 70 and 220 mm (2,8 and 8,7 in) enabling reach almost anywhere
- Adjustable digital volume control up to 32 levels to reach desired volume

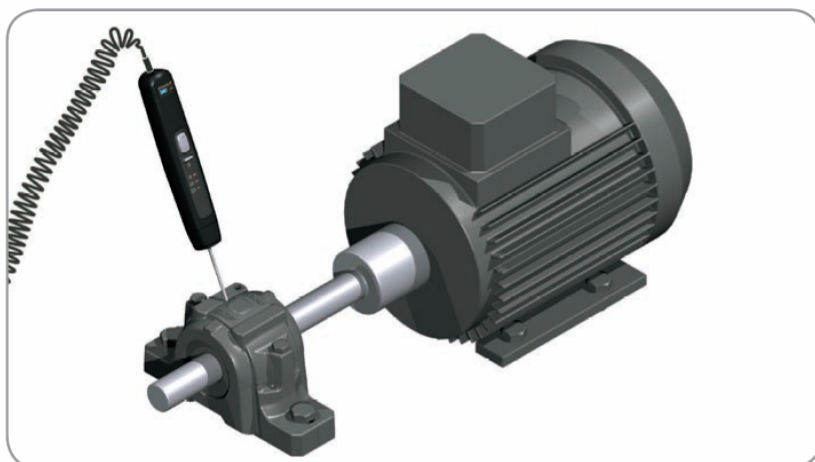

Technical data

Designation	TMST 3
Description	Electronic stethoscope
Frequency range	30 Hz-15kHz
Operating temperature	- 10 to + 45° C (14-113° F)
Output volume	Adjustable in 32 levels
Led indicator	Power on Sound volume Battery low
Maximum recorder output	250 mV
Headset	48 Ohm (with ear defender)
Auto switch off	Yes, after 2 min
Battery	4 x AAA/R03 (included)
Battery lifetime	30 hours (continuous use)
Dimensions handset	220 x 40 x 40 mm (8,6 x 1,6 x 1,6 in)
Probe length	70 and 220 mm (2,8 and 8,7 in)
Weight	
Total weight	1 560 g (3,4 lb)
Instrument	162 g (0,35 lb)
Headset	250 g (0,55 lb)