



*STI Vibration Monitoring Inc.*

www.stiweb.com

# OPERATION MANUAL

## Vibration Input Transmitters and Monitors



CMCP525(A)

CMCP530(A)

CMCP535(A)

CMCP540(A)

CMCP590(A)

 <p>Hazardous Location Safety E112798 UL1604, CSA C22.2 No 213 Cl 1, Div 2, Grp B,C,D 24 VDC, 50 mA Max</p>	<p><b>NOTICE!</b> This equipment is suitable for use in Class I, Division 2, Groups B-D</p>	
--	---	---

### **IMPORTANT!**

**After installation of this unit, no connections are to be made or broken while any connection on the unit is powered up.**

# Table of Contents

- 1.0 General:**
  - 1.1 Model Description
  - 1.2 Power
  - 1.3 Opening the Case
  - 1.4 Dimensions and Mounting
- 2.0 Transmitter:**
  - 2.1 Transducer
  - 2.2 Transducer Cable
  - 2.3 Transducer OK Circuit
  - 2.4 Full Scale Range
  - 2.5 4-20 mA Output
  - 2.6 Buffered Output
  - 2.7 Filter Selection and Installation
  - 2.8 Transmitter Jumper Selection
- 3.0 Monitor Alarm Module:**
  - 3.1 Alert and Danger Setpoints
  - 3.2 Alert and Danger Delay Adjustment
  - 3.3 Latching/Non-Latching Alarms
  - 3.4 Trip Multiply
  - 3.5 Alarm Relays
  - 3.6 Alarm Module Jumper Selection
- 4.0 Test and Calibration Setup:**
  - 4.1 Test Setup
  - 4.2 Zero Calibration
  - 4.3 Full scale (Span) Calibration

## 1.0 General

### 1.1 Model Description:

The CMCP500 Series Transmitters are 4-20mA Output Transmitters. They are ordered and factory configured for use with a low-impedance accelerometer, low-impedance velocity transducer, electro-mechanical velocity transducer or eddy probe. The input signal is processed to determine its overall vibration level in the selected engineering terms. The output is a standard 4-20mA current proportional to the full scale range selected. The 4-20 mA output is suitable for direct connection to a Programmable Logic Controller (PLC) or Distributed Control System (DCS). A BNC connector on the front of the unit provides buffered access to the transducer signal for use with portable analysis instruments.

The CMCP500 Series Transmitters can be also ordered as a standalone Monitor by adding the suffix "A" to the basic model number, i.e.: CMCP5XXA. When ordered in this configuration, the unit includes an alarm module that provides independent set point alarms for both ALERT (A) and DANGER (D) levels. Each set point has a corresponding adjustment potentiometer, a LED indicator on the alarm module front panel, and an output relay that can be configured for either latching or non-latching operation. The alarm LED will turn "ON" and the corresponding relay will actuate whenever overall vibration levels exceed the corresponding set point for more than a preset (jumper selectable) delay time. The alarm module has a front panel accessible BNC connector and associated selector switch for reading the current vibration level (CV) or alarm set points (A or D) with a standard digital volt-meter. The alarm module also provides a transducer "OK" relay, and a Trip-Multiply function. Trip multiply allows the alarm levels to be temporarily increased by a factor of two or three during machine start-up. Both monitors and transmitters mount on standard DIN rail.

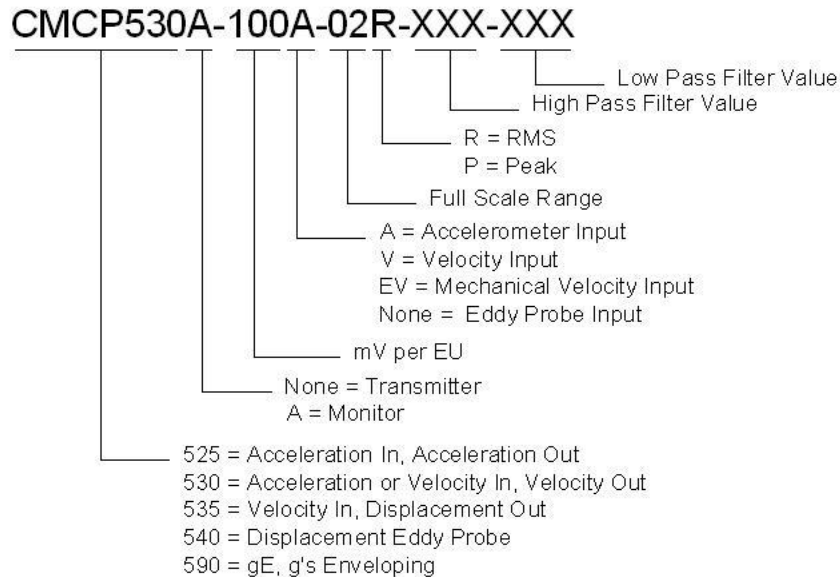

### 1.2 Power:

The CMCP500 Series require externally supplied DC power. The power supply should have a nominal output of +24Vdc and be capable of supplying a minimum of 50mA for each CMCP500 Series Transmitter in the system, or 100 mA for each CMCP500A Series Monitor in the system. A power-supply dedicated to the vibration monitoring system is recommended. It is also recommended that connections between the power-supply and the monitors be made with twisted-shielded instrument cable. The cable shield should float at the monitor / transmitter installation, and connect to common at the power-supply / system common end only. The CMCP500 Series Transmitters and Monitors regulate dc power internally to prevent a fault on

the output of one channel from affecting other channels. When power is first applied to a monitor or transmitter after connecting the transducer, there will be a delay of approximately 30 seconds before the "OK" LED turns "ON".

### 1.3 Opening the Case:

Opening the case is best done with a small flat-blade screwdriver. On transmitters (1" wide units) insert the tip of the screwdriver between the right-side cover (as viewed from the front of the unit) and the DIN rail mounting foot at the back of the unit and gently leverage the blade to begin separating the cover from the rest of the unit. Carefully work your way around to the front of the unit to complete removal of the cover, exposing the circuit board components. On Monitors (1.6" wide units), you must first CAREFULLY separate the two halves of the unit at the center. The sides do not need to be removed. This is done by working the screwdriver around the middle of the unit in the same general manner described above. As the two halves start to become separated, you will see that they are still attached by a short ribbon cable inside. This cable can be carefully removed by pulling it away from the left hand side of the unit. The cable stays with the right hand side permanently. **CAUTION:** When re-installing this cable, make sure it is properly connected to the mating connector, and that the bend in the cable goes towards the front panel side of the unit. IF THE UNIT IS CLOSED WITH THE BEND TOWARDS THE BACK, THE RIBBON CABLE CAN BE DAMAGED. Also, make sure the ribbon cables' connector does not catch on the relays when pressing the unit back together.

### 1.4 Dimensions and Mounting:

CMCP500 Series Transmitters and Monitors are designed to be mounted on Din Standard 35 mm "T" Rail or "G" Rail. They simply snap in place by aligning the top of the mount on the track and pressing down. To remove insert a screwdriver in the tab at the bottom and pull down and out slightly.

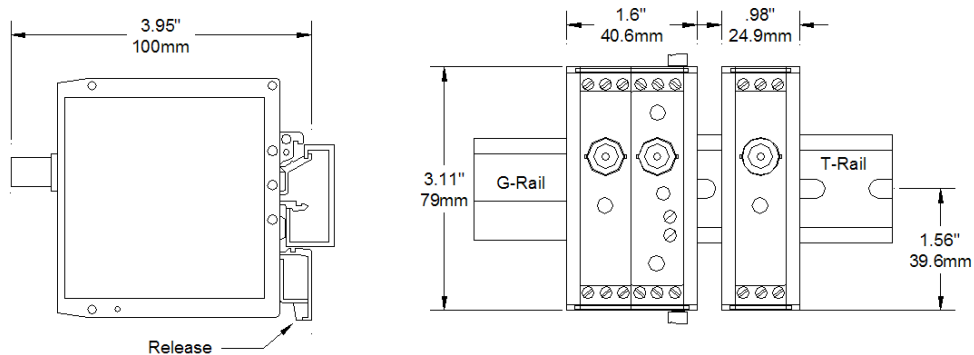

## 2.0 Transmitter

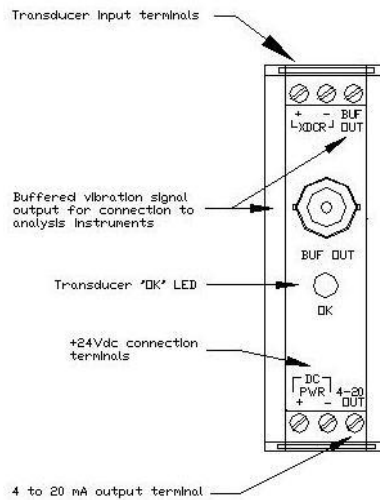

### 2.1 Transducer:

The CMCP500 Series is factory configured for use with one of four transducer types. The specific type is identified by a dash number immediately following the basic part number on the side label. This number is the transducer sensitivity in mV/g, mV/in/sec or mv/mil, followed by an "A" for low-impedance accelerometers (mV/g), "V" for a low-impedance velocity transducers (mV/in/second) or "EV" for electro-mechanical, self-generating velocity transducers (mV/in/sec) or no suffix for eddy probes.

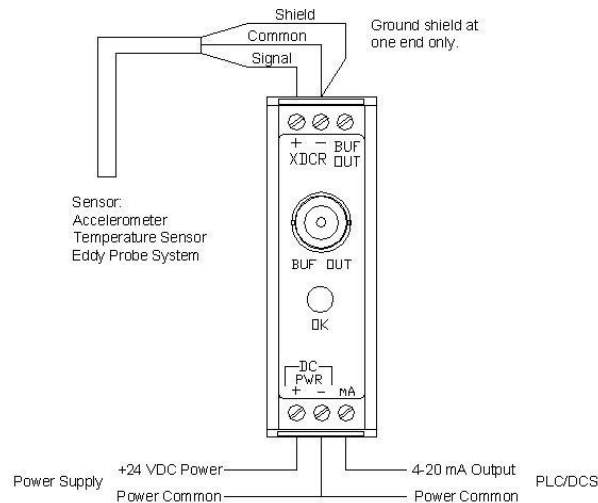

### 2.2 Transducer Cable:

The CMCP500 Series provides power for low-impedance type accelerometers via a nominal 4.4 mA constant current source. This is generally enough current to allow operation with transducer cables extending up to about 150 ft. -24 VDC powered eddy probes must be powered with an external power supply. It is strongly recommended that the monitor / transmitter be mounted as close as practical to the associated transducer. This will prevent signal distortion associated with current drive limitations, and will minimize interference from external electro-magnetic noise sources (EMI). A well shielded, properly installed transducer cable is absolutely necessary to obtain reliable operation. Twisted-shielded pair or triad cables designed and pre-fitted with the proper transducer connector, and sold for this specific purpose are highly recommended. The cable shield should be open at the transducer end, and connected to common (xdcr "-" terminal) at the monitor/transmitter input only. The cable should be routed as far away from other electrical circuits as possible, and run in metal bonded conduit.

### 2.3 Transducer OK Circuit:

The CMCP500 Series incorporates a transducer "OK" circuit. This feature continuously monitors the transducer bias and signal voltage. If this voltage exceeds (over or under) pre-set limits, the 4-20 mA output current is reduced to less than 2 mA (typically 0 mA) to allow detection of the fault condition at the associated PLC or DCS system. A green "OK" LED on the front of the unit ("ON" in an "OK" condition) turns "OFF" to provide a local indication of the fault condition. This circuit will effectively detect open, shorted, or reversed transducer connections. If a fault is detected that subsequently is repaired or goes away, there will be a delay of approximately 30 seconds before the unit returns to the "OK" condition and the "OK" LED turns back "ON". The detected fault will also disable the "ALERT" and "DANGER" alarms/relays until the fault is removed and an "OK" condition exists. NOTE: When configured for use with an electro-mechanical transducer ("EV"), the "OK" circuit will *only* detect an open circuit condition of the transducer / cable.

### 2.4 Full Scale Range:

The CMCP500 Series is supplied factory calibrated for the full-scale range specified at the time of order. Other ranges may be implemented (see table below) by changing the positions of internal jumpers as indicated in the table below. See "Opening the case" to gain access to these jumpers. Changing range jumpers without further re-calibration will introduce an additional reading error of 2% maximum. For greater accuracy the unit must be re-calibrated. (See Section 2.8: "Transmitter Jumper Settings") The factory calibrated range is listed on the side label as a dash number. Custom ranges are available.

Range	CMCP525	CMCP530	CMCP535/540
-01	0-5.0 g's	0-0.5 in/sec (0-25.4 mm/sec)	0-5.0 mils (0-127.0 microns)
-02	0-10.0 g's	0-1.0 in/sec (0-50.8 mm/sec)	0-10.0 mils (0-254.0 microns)
-03	0-15.0 g's	0-1.5 in/sec (0-76.2 mm/sec)	0-15.0 mils (0-381.0 microns)
-04	0-20.0 g's	0-2.0 in/sec (0-101.6 mm/sec)	0-20.0 mils (0-508.0 microns)
-05	0-25.0 g's	0-2.5 in/sec (0-127.0 mm/sec)	0-25.0 mils (0-635.0 microns)

### 2.5 4-20 mA Output:

The primary output of the monitor/transmitter is the 4-20 mA current output which is proportional to the full scale range of the unit. IE: If the range is 0 – 1.0, then 4 mA indicates a reading of 0.0 and 20 mA indicates a reading of 1.00. This output is intended to drive a maximum resistive load of 600 Ohms with respect to system common at the PLC/DCS input. A precision 250 Ohm resistor is the recommended load if the IO Module is not equipped. This will convert the 4-20 mA current reading into a 1-5 Vdc reading for the PLC/DCS. A short to ground (common) on this output *will not* damage it.

### 2.6 Buffered Output:

The CMCP500 Series provides buffered access to the transducer signal via a BNC connector on the front of the unit. This output has the same sensitivity, units, and bias voltage as the transducer itself. i.e.: mV/g for an accelerometer or mV/in/sec for a velocity transducer. This output can be connected to portable analysis instruments, or can be used to check the bias-output-voltage (BOV) of low-impedance transducers using a digital volt-meter. The Buffered output is un-filtered. The buffered output signal is also available on a screw terminal at the top of the unit. Buffered output for -24 VDC eddy probes is flipped and will be a +VDC value.

**NOTE:** For Electro-Mechanical (self-generating) type velocity transducers with an output sensitivity of 135 mV/in/sec or greater, the buffered output is scaled to 100 mV/in/sec. i.e.: A 145 mV/in/sec transducer will result in a buffered output (BNC) sensitivity of 100 mV/in/sec.

## 2.7 Filter Selection and Installation:

Filters for use with the CMCP500 series transmitters and monitors are modular and may be factory or field installed. Filter modules have a 4-pole Butterworth response which attenuates frequencies beyond the specified corner frequency by approximately -24dB/octave. The Corner frequency as defined by standard convention is the frequency at which the filter attenuates the signal by -3dB, or approximately 30%. For Low-Pass filters, signals frequencies less than 60% of the specified corner frequency are attenuated less than 1%, and for frequencies less than 75% of the corner, attenuation due to the filter is less than 5%. For High-Pass filters the numbers translate to 1.66 times the corner, and 1.33 times the corner for 1% and 5% attenuations respectively. Filters modules can be ordered with corner frequencies from as low as 5 Hz (300 RPM) to 2000 Hz (120,000 RPM). High-Pass and Low-Pass filters can be cascaded to form a Band-Pass response but care must be taken to assure that the specified corner frequencies are far enough apart to minimize attenuation due to corner interaction in the Pass-Band. Usually a factor of 5 or more between corners will work. When installing filters, you will be working in direct contact with sensitive electronic components. To assure your safety and to avoid damaging the unit you must first disconnect and remove the unit from its installation. You must also make sure you do not accidentally cause a static discharge to any part of the unit. This is best accomplished by wearing an anti-static ground strap around your wrist while working on the unit. At a minimum, touch a grounded metal object to discharge yourself prior to handling the open unit.

Step 1: To install filter modules you must first open the monitor/transmitter. Refer to Section 1.3 "Opening The Case".

Step 2: With the cover removed you will notice two 16-pin sockets near the rear of the printed circuit board. These are where you will install the filter modules. You should also locate jumpers E1 and E5 which are next to the sockets. **(CAUTION: TO AVOID DAMAGING THE UNIT, DO NOT TOUCH ANY CIRCUIT BOARD COMPONENTS OTHER THAN THOSE INDICATED BELOW).**

Step 3: To install a **High-Pass** filter module, first remove jumper **E5**, then install the filter module in the socket marked **U12** (this is the socket in the corner). Use care to assure that you align pin 1 of the module (indicated on its label) with pin 1 of the socket (the pin next to the U12 marking). Note: Filters only have 5 pins.

Step 4: To install a **Low-Pass** filter module, first remove jumper **E1**, then install the filter module in the socket marked **U9** (this is the socket closest to the center-rear of the circuit board). Use care to assure that you align pin 1 of the module (indicated on its label) with pin 1 of the socket (the pin next to the U9 marking).

Step 5: Re-assemble the unit.

## 2.8 Transmitter Jumper Selection:

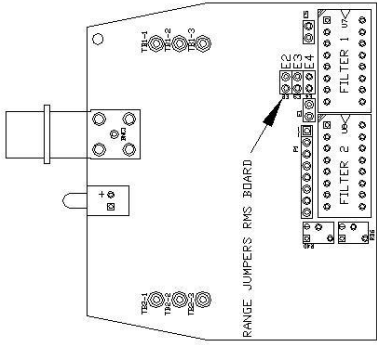

INSTALL JUMPER	CMCP 525	CMCP 530	
		ENGLISH	METRIC
E2	5.0 g/s	0.5 in/sec	12.5 mm/sec
E3	10.0 g/s	1.0 in/sec	25.0 mm/sec
E2, E3	15.0 g/s	1.5 in/sec	37.5 mm/sec
E3, E4	20.0 g/s	2.0 in/sec	50.0 mm/sec
E2, E3, E4	25.0 g/s	2.5 in/sec	62.5 mm/sec

**CMCP525/530 RMS Range Selections**

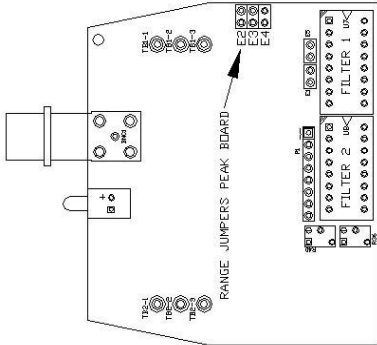

INSTALL JUMPER	CMCP 525	CMCP 530		CMCP 535/540 PEAK TO PEAK	
		ENGLISH	METRIC	ENGLISH	METRIC
E2	5.0 g/s	0.5 in/sec	12.5 mm/sec	5 MILS	127 MICRONS
E3	10.0 g/s	1.0 in/sec	25.0 mm/sec	10 MILS	254 MICRONS
E2, E3	15.0 g/s	1.5 in/sec	37.5 mm/sec	15 MILS	381 MICRONS
E3, E4	20.0 g/s	2.0 in/sec	50.0 mm/sec	20 MILS	508 MICRONS
E2, E3, E4	25.0 g/s	2.5 in/sec	62.5 mm/sec	25 MILS	635 MICRONS

**CMCP525/530/535/540 Peak Range Selections**

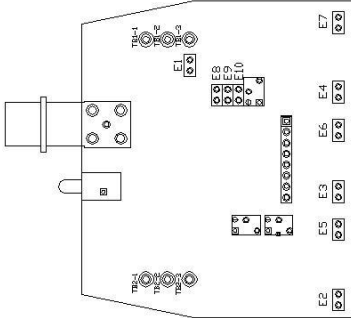

INSTALL JUMPER	CMCP 590
E1	CCD 'ON'
E2, E5	ENV FILTER #4
E3, E6	ENV FILTER #3
E4, E7	ENV FILTER #2
E8	10 gE RANGE
E9	30 gE Range
E10	80 gE Range

**CMCP590 Jumper Selections**



### 3.0 Monitor Alarm Module (If Equipped):

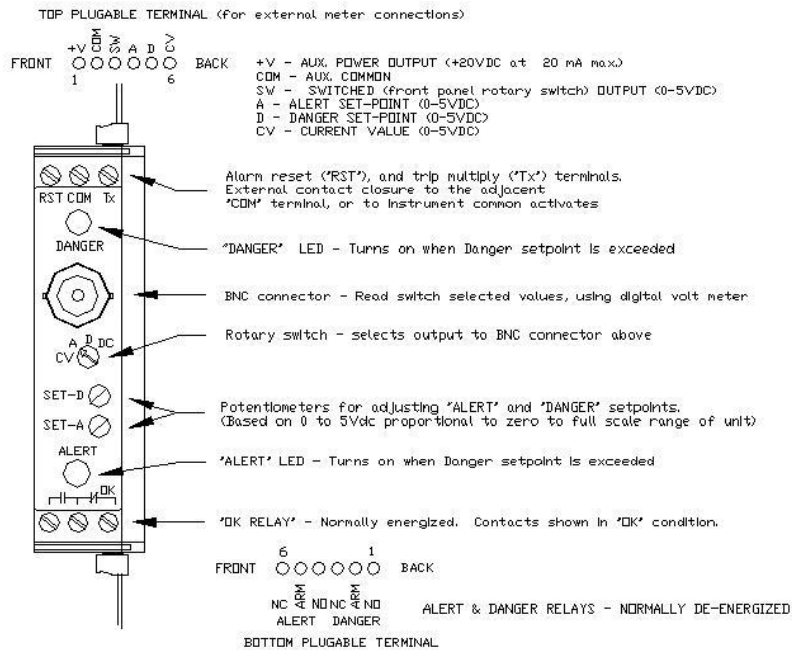

#### 3.1 Alert and Danger Alarm Set-Point Adjustment:

The Alert and Danger alarm set-points can be independently set in the field by turning the front panel selector switch to the associated position (A or D) and adjusting the associated front-panel potentiometer until the correct DC voltage is measured at the BNC connector located directly above the selector switch. Adjusting the set-point requires the use of a digital volt-meter, knowledge of the full scale range of the monitor, and the desired set-point as a percentage of the full scale range. The voltage measured at the BNC will vary between 0 Vdc and 5 Vdc, corresponding to 0 to Full-scale. i.e.: 2.5 Vdc represents 50% of full scale, 3.75 Vdc represents 75% of full scale. To calculate the required set point voltage if the unit is not equipped with a display, use the equation,  $5(.xx)$  where .xx is the desired percentage expressed as a decimal fraction of the full scale range. i.e.:  $5(.60) = 3.00$  Vdc for a set-point of 60% of the full scale range. Turning the potentiometer clockwise increases the set point voltage.

#### 3.2 Alert and Danger Alarm Delay Adjustment:

The Alert and Danger alarm delays can be independently set by internal jumper selection to 0.1, 1.0, 3.0, 6.0, or 10.0 seconds. The purpose of the delay is to reduce nuisance alarms caused by external electrical noise and/or transient vibration events. Both the Alert and Danger delay are factory set to the 3 second position. To change the delay, open the unit and move the delay jumpers to the proper position (Refer to Section 3.6 "Alarm Module Jumper Settings").

### 3.3 Latching/Non-Latching Alarms:

The Alert and Danger alarms are factory set for NON-LATCHING operation. This means that whenever the vibration level drops below the associated set-point for more than about 1 second, the associated relay will de-energize and the alarm LED will turn off. The alarms can also be set for LATCHING operation by installing shunts on jumpers E1 and E2 respectively on the Alarm module circuit board (See: CMCP500 SERIES ALARM MODULE JUMPER LOCATIONS, at the back of this manual). Latched alarms may be reset by closing the RESET (RST) and COMMON (COM) contacts at the top of the unit. This may be done with an external switch, dry contact relay, or by shorting the terminals together by hand. **DO NOT APPLY VOLTAGE TO EITHER THE "RST" or "COM" TERMINALS.** If several monitors are mounted together, the "RST" terminals may be daisy-chained together.

### 3.4 Trip Multiply:

The alarm module provides a trip multiply feature. This feature allows the user to temporarily double (standard) or triple (jumper selectable) the normal set points during periods of normal high vibration such as start-ups. To actuate the trip multiply feature, the Tx terminal at the top of the alarm module must be closed to the adjacent "COM" terminal. This may be done with an external switch, dry contact relay, or by shorting the terminals together by hand. **DO NOT APPLY VOLTAGE TO EITHER THE "Tx" or "COM" TERMINALS.** If several monitors are mounted together, the "Tx" terminals may be daisy-chained together and switched to "COM" (system common) as a group.

### 3.5 Alarm Relays:

The Alert Danger and OK relays are independent, single-pole-double throw relays. NO, ARM, and NC contacts are available via plugable screw-connector at the bottom of the monitor. OK relay contacts are available on fixed screw terminals at the bottom front of the alarm module (Refer to Section 3.0 "Monitor Alarm Module). Relay contacts are rated 5 Amps at 30 Vdc or 125 Vac, resistive load. This rating includes any inrush current that the load draws. For loads that are not purely resistive the contact switching capability will need to be considered carefully in terms of this inrush current. The entire subject of relay application is too large to address here, so the user is cautioned to use care in the application of the relays. The factory intended purpose of providing relay contacts is to operate relatively low power alarm annunciators, act as a dry or low dc voltage contact closure input to other systems, or act to actuate an appropriately sized slave relay for larger loads such as shutting down a motor. Relays are socketed and can be replaced.

### 3.6 Alarm Module Jumper Selection:



1. Connect the test instruments listed above as shown on the Test/Calibration drawing.
2. With the signal generator **OFF**, measure the output current from the mA terminal, using digital current-meter.
3. Wait until the output has completely settled to a stable value, and then adjust potentiometer (farthest from the circuit board edge) until the output is 4.00 +/- .05 mA.

#### **4.3 Full-Scale (SPAN) Calibration:**

The full-scale output has been factory calibrated. It should only need to be checked or adjusted once every two years under normal use. However, should adjustment become necessary (such as with a range change) complete the following steps.

1. Connect the test instruments listed above as shown on the Test/Calibration drawing.
2. Calculate the proper full-scale test input voltage from the following options:
3. Turn on the signal generator, set the correct frequency and amplitude for the appropriate full scale RMS or Peak voltage as measured with a True-RMS digital volt-meter **directly at the + transducer input terminal**. Measure the output current using the digital current-meter. Wait until the output has settled to a stable value, and then adjust potentiometer (closest to the circuit board edge) until the output is 20.00 mA +/- .05 mA. Turning the potentiometer clockwise increases the output.

**(Note: CMCP590(A) gE Transmitter must be Factory Calibrated.)**