



SKF TKBA 10 & 20

Instructions for use

Table of contents

| | |
|--|----|
| EC Declaration of conformity..... | 4 |
| Safety recommendations..... | 5 |
| 1. Introduction..... | 6 |
| 2. Principle of operation | 7 |
| 3. Battery installation | 8 |
| 4. Mounting the units | 9 |
| 5. Power on..... | 9 |
| 6. Alignment Condition check..... | 10 |
| 7. Correcting misalignment..... | 10 |
| 8. Troubleshooting and maintenance | 13 |
| 9. Technical data | 13 |

EC Declaration of conformity

We,
SKF Maintenance Products
Kelvinbaan 16
3439 MT Nieuwegein
The Netherlands

herewith declare that the following product:

SKF Belt Alignment Tool TKBA 10 and TKBA 20

has been designed and manufactured in accordance with:
EMC DIRECTIVE 2004/108/EC as outlined in the harmonized norm for
EN 61000-6-2:2005 - Immunity for Industrial Environments,
IEC 61000-4-2:2001, IEC 61000-4-3:2008, IEC 61000-4-8:2001

EN 61000-6-3:2007 - Emission Standard for Residential, Commercial
and light Industrial Environments,
CISPR 16-1-4:2012, CISPR 16-2-3:2010,
CISPR 16-1-1:2010, CISPR 16-1-5:2012

The laser is classified in accordance with the
USA FDA Standard 21 CFR, Ch 1, Part 1040.10 and 1040.11

EUROPEAN ROHS DIRECTIVE 2011/65/EU

Nieuwegein, The Netherlands,
October 2013



Sébastien David
Manager Product Development and Quality



Safety recommendations

- Always turn off the power of the drive machine before you start working.
- Always read and follow the operating instructions.
- Never stare directly into the laser beam.
- Never aim the laser beam into another person's eyes.
- Opening the housing of the laser unit may result in hazardous light exposure and void the warranty.
- Take care not to pinch your fingers when mounting the units on the pulley.
- The equipment should not be used in areas where there is a risk of explosion.
- Never expose the equipment to high humidity or direct contact with water.
- Have all repair work performed by an SKF repair shop.



1. Introduction

Precise alignment of belt driven machinery is essential to reduce both pulley and belt wear. It can help reduce machinery vibration, which in turn leads to improved machine performance.

Good pulley alignment can help reduce unscheduled downtime, and can improve the reliability of your equipment.

The SKF Belt Alignment Tools TKBA 10 and TKBA 20 offer an easy and accurate method to adjust the machinery so that pulleys are accurately aligned.



2. Principle of operation

The TKBA 10 and TKBA 20 consist of two units that attach magnetically to the side of each pulley. The transmitter unit emits a laser line that is projected onto the reflector unit. The reflector unit has a target area with a central reference line. The laser line is then reflected to the transmitter unit for a reading on the second target area, greatly increasing the accuracy. Depending on the position and orientation of the laser line projected on the target areas, it is possible to determine the type of misalignment and how to correct it. Belt alignment is easily performed by adjusting the moveable machine(s) until the laser lines coincide with the reference lines on both units.

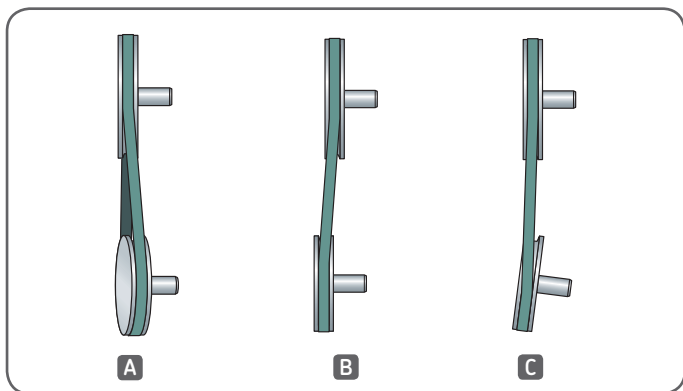

Figure 1: Different types of pulley misalignment

| | |
|----------|-------------------------------|
| A | Vertical angle misalignment |
| B | Parallel misalignment |
| C | Horizontal angle misalignment |

3. Battery installation

The TKBA 10 and 20 are powered with 2x AAA LR03 alkaline batteries.

To insert the new batteries:

- Locate the “Remove to Release battery pack” sticker on the end of the transmitter unit.
- Remove the two cross-head screws (Fig.2).
- Take out the battery pack holder by pulling on the white strip (Fig.3).
- Carefully insert two new batteries in the holder taking care to observe polarity. Replace the battery pack holder in the unit and refit the screws.



Figure 2: Battery door



Figure 3: Pull on the white strip

Note: Remove the batteries if the transmitter unit is to remain unused for an extended period.

4. Mounting the units

The TKBA 10 and TKBA 20 are equipped with a powerful magnet bracket assembly, allowing the operator to mount the system on almost any pulley face.

Mount the units on the pulley faces to be aligned.

- The reflector unit should be mounted onto the pulley to be moved or adjusted.
- The transmitter unit should be mounted on the stationary pulley.

The user must determine which pulley is movable and which is stationary. The movable pulley is often the smallest one, and is often mounted on the motor shaft. In some cases both pulleys and shafts may need to be adjusted to achieve the desired alignment.

For non-ferrous pulleys or sprocket, it is possible to use a small bar clamp (G clamp).



Figure 4: Units mounted on pulleys

5. Power on

To turn the laser line on, use the rocker switch located on the side of the transmitter unit.

6. Alignment Condition check

The laser line on the reflector unit shows the vertical angle misalignment and parallel misalignment or offset. Horizontal angle misalignment is indicated by the position of the reflected laser line on the transmitter unit.

Before aligning the pulleys it is important that the pulleys are mounted correctly on the shafts and that the shafts are straight. Buckled pulleys will have a detrimental effect on the alignment quality.

7. Correcting misalignment

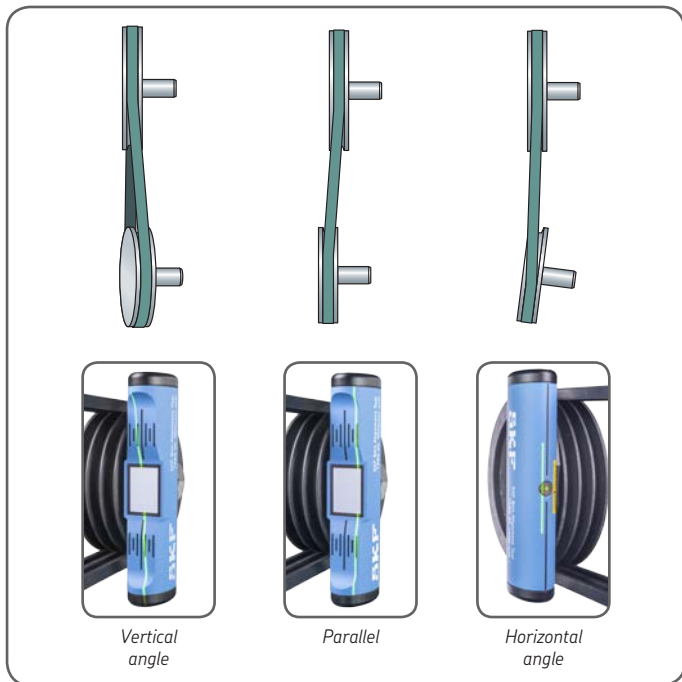

Figure 5: Misalignment summary

Step 1:

Correct vertical angle misalignment by shimming the moveable machine using stainless steel shims such as SKF TMAS shims. Correction of this angular misalignment can be observed on the reflector unit.

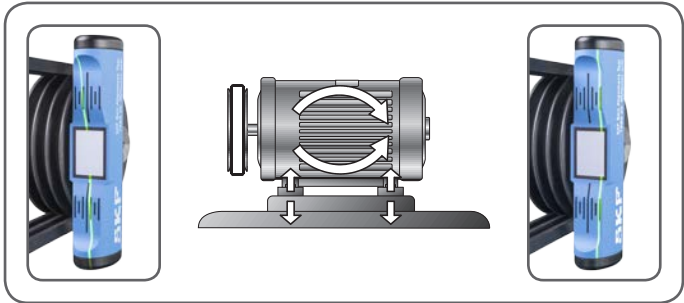

Figure 6: Vertical angle misalignment as found and after correction

Step 2:

Correct horizontal angle misalignment by adjusting the moveable machine laterally. This can be viewed on the laser unit during adjustment.

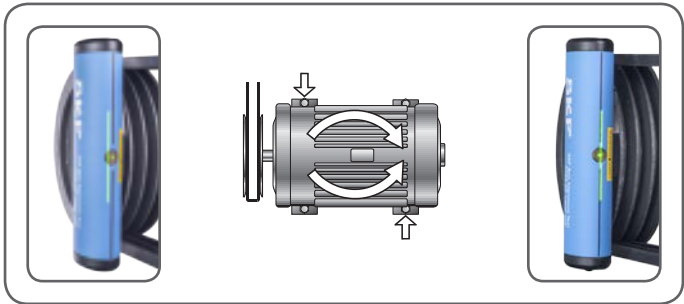

Figure 7: Horizontal angle misalignment as found and after correction

Step 3:

Correct parallel misalignment (Offset) by adjusting the moveable pulley or machine axially. This correction can be observed on the reflector unit.

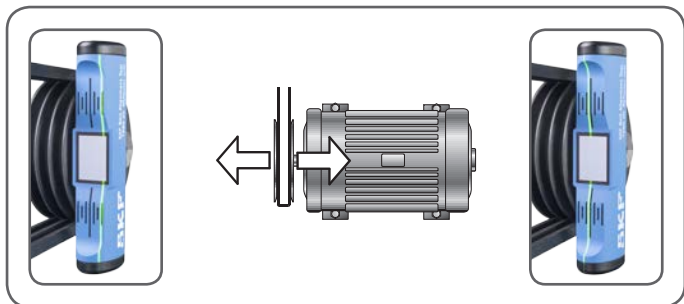

Figure 8: Parallel misalignment as found and after correction

If Steps 1, 2 and 3 are followed then the alignment of the belt drives should be completed quickly. However, one alignment correction may affect other alignment conditions. Steps 1, 2 and 3 may need to be repeated until the system is completely aligned.

Good alignment is achieved when the laser lines on the transmitter and reflector units coincide with the reference lines.



Figure 9: Pulleys perfectly aligned

Note: When tightening the belt, check the horizontal angle alignment and adjust if necessary.



WARNING: Switch OFF the transmitter unit and remove both units BEFORE starting machinery.

8. Troubleshooting and maintenance

No laser line

- Check that the batteries are inserted correctly in the transmitter unit.
- Replace the batteries.
- Ensure that the laser window in the transmitter unit is not obstructed by dirt. If necessary, clean with cotton cloth.

Lost calibration

If the tool loses its calibration, return the complete tool to SKF for repair.

Heavy impacts

The transmitter unit is equipped with sensitive optical components. Heavy impacts can affect the function and accuracy of the unit. Handle with care and ensure that the laser window is kept clean and free from dirt.

9. Technical data

| Designation | TKBA 10 | TKBA 20 |
|------------------------------|--|--|
| Transmitter Unit | | |
| Type of laser | Red laser diode | Green laser diode |
| Laser line length | 2 m at 2 m (6.6 ft at 6.6 ft) | 2 m at 2 m (6.6 ft at 6.6 ft) |
| Measurement Accuracy Angular | Better than 0,02° at 2 m (6.6 ft) | Better than 0,02° at 2 m (6.6 ft) |
| Measurement Accuracy Offset | Better than 0,5 mm (1/50" in.) | Better than 0,5 mm (1/50" in.) |
| Measurement distance | 50 mm to 3 m (2 in to 10 ft) | 50 mm to 6 m (2 in to 20 ft) |
| Control | Laser ON/OFF rocker switch | Laser ON/OFF rocker switch |
| Housing Material | Aluminum, Powder coat finish | Aluminum, Powder coat finish |
| Transmitter unit dimensions | 169 x 51 x 37 mm (6.65 x 2.0 x 1.5 in.) | 169 x 51 x 37 mm (6.65 x 2.0 x 1.5 in.) |
| Transmitter unit weight | 450 g (1.0 lbs) | 450 g (1.0 lbs) |
| Receiver Unit | | |
| Housing Material | Aluminum, Powder coat finish | Aluminum, Powder coat finish |

| | | |
|---------------------------|---|---|
| Reflector dimensions | 22 x 32 mm (0.9 x 1.3 in.) | 22 x 32 mm (0.9 x 1.3 in.) |
| Receiver unit dimensions | 169 x 51 x 37 mm (6.5 x 2.0 x 1.5 in.) | 169 x 51 x 37 mm (6.5 x 2.0 x 1.5 in.) |
| Receiver unit weight | 430 g (0.9 lbs) | 430 g (0.9 lbs) |
| Fixtures | | |
| Mounting | Magnetic, side mounted | Magnetic, side mounted |
| Battery and Power | | |
| Battery | 2 x AAA Alkaline type IEC LR03 | 2 x AAA Alkaline type IEC LR03 |
| Operation time | 25 hours continuous operation | 8 hours continuous operation |
| Size | | |
| Carrying Case dimensions | 260 x 180 x 85 mm (10.2 x 7.1 x 3.3 in.) | 260 x 180 x 85 mm (10.2 x 7.1 x 3.3 in.) |
| Total weight (incl. case) | 1,4 kg (3.0 lbs) | 1,4 kg (3.0 lbs) |

| Designation | TKBA 10 | TKBA 20 |
|-------------------------------|------------------------------------|------------------------------------|
| Operating Requirements | | |
| Operating temperature | 0 to 40 °C (32 to 104 °F) | 0 to 40 °C (32 to 104 °F) |
| Storage temperature | -20 to +60 °C (-4 to +140 °F) | -20 to +60 °C (-4 to +140 °F) |
| Relative Humidity | 10 to 90% RH non-condensing | 10 to 90% RH non-condensing |
| IP rating | IP 40 | IP 40 |
| Calibration certificate | Valid for two years | Valid for two years |
| Case contents | | |
| | 1x TKBA 10 transmitter unit | 1x TKBA 20 transmitter unit |
| | 1x TKBA 10 receiver unit | 1x TKBA 20 receiver unit |
| | 2x AAA batteries | 2x AAA batteries |
| | 1x printed Instructions for Use | 1x printed Instructions for Use |
| | 1x Calibration certificate | 1x Calibration certificate |

The contents of this publication are the copyright of the publisher and may not be reproduced (even extracts) unless prior written permission is granted. Every care has been taken to ensure the accuracy of the information contained in this publication but no liability can be accepted for any loss or damage whether direct, indirect or consequential arising out of the use of the information contained herein.

SKF Maintenance Products

www.mapro.skf.com
www.skf.com/mount

MP5428EN

© SKF is a registered trademark of the SKF Group.
© SKF Group 2013/11